

**127mm (5inch) Twin-wall Flue Pipe - SFL IL**

**Twin-wall flue pipe** is used to connect the Dunbrik Mini Clearflow concrete gas flue block system (pre-cast flue) through the roof space to a gas flue terminal outlet, either at the ridge, at eaves or through the roof slope.

SFL IL pipe is manufactured with an aluminium inner liner of a nominal internal flue diameter of 127mm and a Zalutite outer casing separated by a 6mm air gap which insulates the flue from low external temperatures. It complies with BSEN1856-1 for internal or external use. The flue pipe is available in straight lengths, bends and terminals which twist lock together to make a rigid system.

**Components**

**STWBC Flue block connector** - To connect twin-wall pipe to the 4M or 5M concrete transfer blocks or as an adaptor to connect SFL IL to other pipes and secured with gas tape.

**STW090 Adjustable bend.** - A five segment elbow bend. Segments rotate to achieve up to 45° bends in a gas flue.

**Straight pipe lengths** - the overall length includes 38mm of overlapping connection.

Product Code	Length		Net length mm
	Inch	mm	
STW60	60	1524	1486
STW36	36	914	876
STW18	18	457	419

Product code	Length		Net length mm
	inch	mm	
STW12	12	305	267
STW6	6	152	114

**STW18A Adjustable length pipe** (This needed as pipe should not be cut to length) - Overall length of 457mm including a 25mm collar. It slides over a fixed length pipe to achieve flue lengths between 75mm and 356mm. Secured with a tespa screw band.

**STWB245 Wall band** - Bracket adjustable to 245mm clearance to support the flue pipe in the roof space.

**STWB50 Wall band** - Bracket with fixed 50mm clearance to support the flue pipe in the roof space.

**STWAF0530 Angled Flashing** - Aluminium flashing for use on pitched roofs with an angle of between 5° and 30°. Requires an **STWSC** storm collar with sealant. The flashing is not suitable for profiled roof tiles.

**STWGVV Gas Vent Terminal** - Fabricated aluminium terminal.

**STWRVTA Ridge Tile Adaptor** - To convert 127mm round flue pipe to a rectangular shape for connecting a slotted ridge vent terminal. (Not required for Dunbrik Gastyle 2 or Dunvent terminals)

**STWRVIL Adaptor from Bvent to SFL IL** - For connecting Bvent pipe upwards into a SFL IL pipe.

**STWST Sealing tape** - 50mm wide self adhesive aluminium sealing tape.

**Installation guidance**

For connecting the Dunbrik domestic concrete gas flue system through twinwall flue pipe to a gas terminal.

Please read the Mini Clearflow installation guide for details of the gas flue block system.

Do not use single skin or flexible pipe. Do not cut the flue pipe (use an adjustable length). Maintain a minimum clearance of 25mm from twin-wall flue pipe to combustible materials.



**Installation steps**

- Flue pipe must be fitted by a competent/approved gas installer and tested prior to the installation of the fire.
- Cement an **STWBC** flue block connector using cement/water paste, into the concrete gas flue transfer block (code 4M or 5M) and leave to set before joining the first piece of twin-wall pipe
- Join each pipe section by aligning the dimples on the couplers and push fitting together with the inserted piece pointing upwards. Twist the upper pipe 1/6 turn clockwise to complete the connection.
- Use **STW090** adjustable bends, to angle the pipe from the transfer block near to fixing points in the roofspace and back to vertical at the terminal. Twist the segments to the required bend, not exceeding 45 degrees.
- Use an **STW18A** adjustable length, to achieve lengths of 75mm to 356mm by sliding the **STW18A** over the straight pipe below it. Secure the pipe by tightening the fixing band supplied around the bottom of the adjustable length.
- Use **STWB245** wall bands, to support the pipe within the roof space so that it does not pull on the connection to the flue terminal. Screw to a wall or batten to support the flue pipe at not more than 1.8 metre centres.
- Use **STWAF0530** angled flashing and an **STWSC** storm collar when going through the roof slope to provide weather proofing. Nail or screw fix the base of the flashing to the roof battens above the cone section prior to tiling and lap the roof tiles over the flashing base. Seal the flashing to the flue pipe. Fit the storm collar and seal it to the flue pipe. The flashing kit is not suitable for profiled roof tiles.
- Fit an **STWGVV** gas vent terminal, when terminating through the roof slope or at eaves. Twist-lock the terminal to the final section of pipe with the standard twist lock connection.
- Support any pipe higher than 1 metre above the roof breakout point using a guywire bracket **STWGWV** and rigid angle-iron stays to allow for local wind-loading.
- Connect directly to a Dunbrik **Gastyle** or **Dunvent** ridge vent terminal (these have a standard IL connection).
- When connecting to a ridge vent with a rectangular shape connection, fit an **STWRVTA** ridge tile adaptor.
- On completion check that the full flue pipe run to the terminal is a permanent secure connection.

A flue draw test should be carried out in accordance with BS5440:Part 1:1990 or IS:813 2002 in order to ascertain the satisfactory operation of the complete flue system. It should be carried out by a Corgi registered fitter in the UK or trained gas fire installer in Ireland. Should any smoke seepage be observed from joints or seams of the IL flue then those joints and seams should be taped using 50mm wide aluminium sealing tape ref. **STWST**. If you need further advice, contact our technical staff on 01924 373694.

Component diagrams

**Straight pipe lengths**

**Flue block connector**

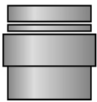

**STWBC**  
Length 168mm  
Flue length 110mm



**STW6**



**STW12**



**STW18**





**STW36**

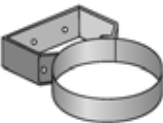

**STW60**

<b>Product code</b>	<b>STW6</b>	<b>STW12</b>	<b>STW18</b>	<b>STW36</b>	<b>STW60</b>
<b>IL ref.</b>	0421305	0421205	0421105	0420305	0420105
<b>Pipe length</b>	152mm	305mm	457mm	914mm	1524mm
<b>Net flue length</b>	114mm	267mm	419mm	876mm	1486mm

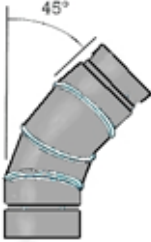
<p><b>Adjustable length</b> net 75mm to 356mm</p>  <p><b>STW18A</b> 0421605</p>	<p><b>Wall band</b> 50mm</p>  <p><b>STWB50</b> 0428805</p>	<p><b>Adjustable Wall Band</b> up to 245mm</p>  <p><b>STWB245</b> 0429805</p>	<p><b>Adjustable bend</b> zero to 90°</p>  <p>use up to 45°</p> <p><b>STW090</b> 0422105</p>
--	---	---	---

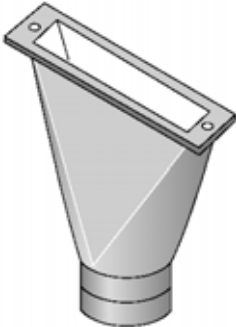
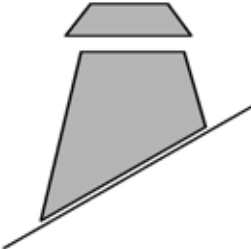
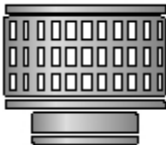
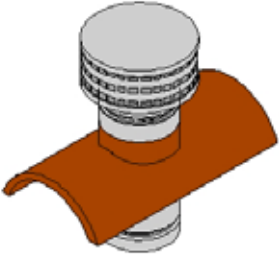
<p><b>Ridge Tile adaptor</b></p>  <p><b>STWRTA</b> 0401805</p>	<p><b>Adjustable flashing</b> 5° to 30°</p>  <p>with storm collar</p> <p><b>STWAF0530 &amp; STWSC</b> 700503003 &amp; 70123403</p>	<p><b>Gas vent Terminal</b></p>  <p><b>STWGV</b> 0407305</p>	<p><b>Gastyle</b> ridge vent terminal</p>  <p>In three tile shapes and six colours</p>
---	---	--	---