

SMW

Twin-Wall, Insulated
Stainless Steel
Multi-Fuel
Chimney Systems

DIAMETER RANGE
127mm-355mm (5"-14")

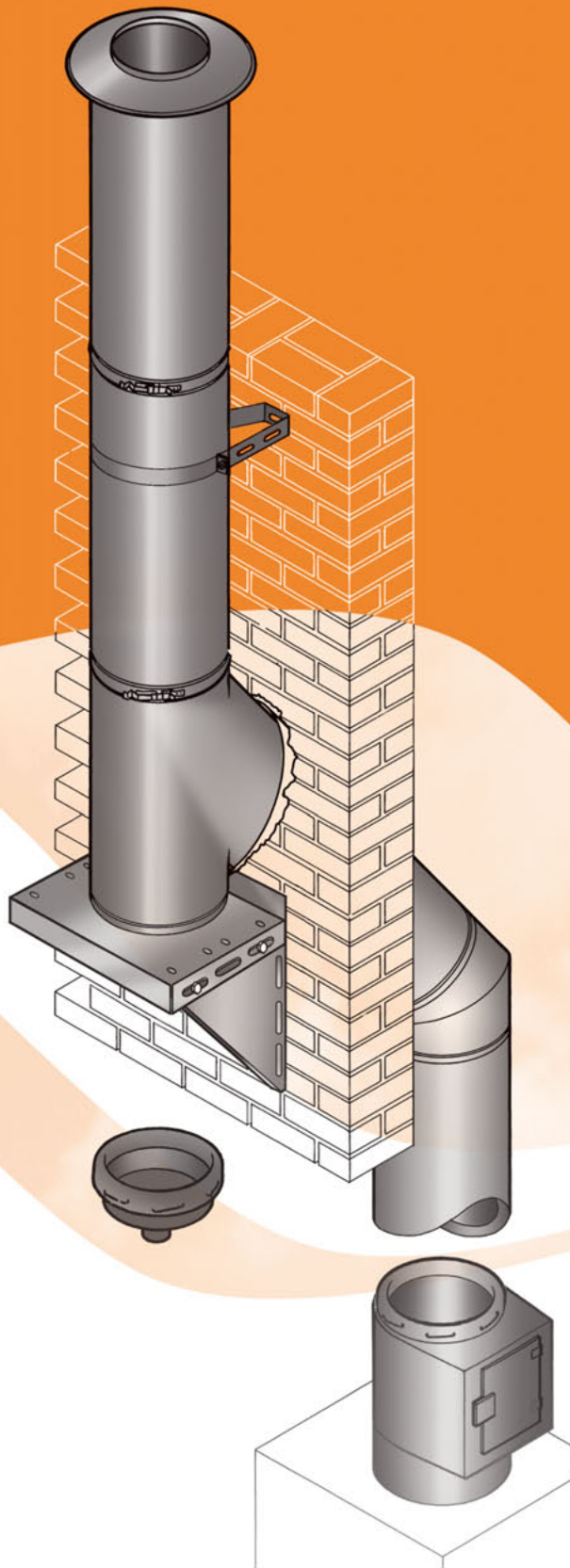

Product Information

The SMW Chimney Systems is designed to be used for Solid, Multi-Fuel, Oil and Gas fired combustion equipment where using the appropriate Support Components. The system is not designed for, and should not be used for positive pressure applications.

Multi Fuel Chimney System Twin Wall, Insulated Stainless Steel

Introduction

SMW is a pre-fabricated twin wall insulated chimney system and has been designed specifically to be used on Solid, Multi-fuel, Gas and Oil fired combustion equipment, operating under negative draught conditions. Under no circumstances should SMW be used on appliances that generate excessive condensation such as condensing appliances or where the chimney system has been designed to operate under positive pressure conditions.

The SMW product is manufactured to the highest quality and is CE Marked to BS EN 1856-1, suitable for appliance with flue gas temperatures up to 450°C.

The system consists of straight pipe lengths and associated fittings, which are constructed entirely from stainless steel and have a 25mm insulated annulus. The external casing is weatherproof and carries the structural load, while the inner liner is manufactured from a high grade 316 stainless steel, offering excellent protection from the often corrosive products of combustion and is free to expand or contract as the flue gas temperatures change.

SMW can be used either internally or externally. The relatively low external wall temperature permits installation with only a 50mm air gap clearance to combustible material. The distance to combustible material is related to the thermal testing procedure as defined in BS EN 1856-1 / BS EN 1859.

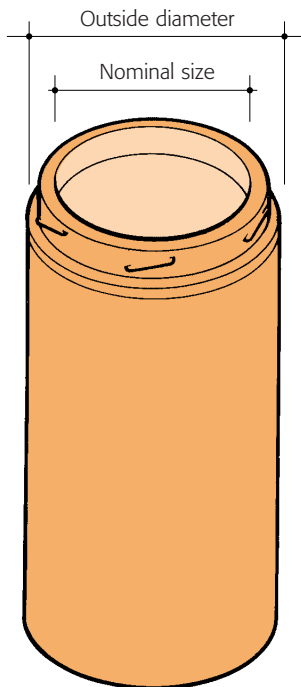

SMW Product Designation To BS EN 1856-1

Cert. No: 086-CPD-496040	SMW	BS EN 1856-1	T450	N1	D	Vm	L50040	G(50)
Standard Number								
Temperature Level <= 450°C								
Pressure Level								
Condense Resistance D = Dry W = Wet								
Corrosion Resistance								
Material Specification Liner = Grade 316 S/S Liner Thickness 0.4mm								
Sootfire Resistance G = Yes O = No (xx) = Distance to combustible material								



Nominal size (internal diameter)	Outside diameter	Cross-sectional area
127mm (5in)	175mm (7in)	12 668mm ² (20in ²)
152mm (6in)	200mm (8in)	18 146mm ² (28in ²)
178mm (7in)	230mm (9in)	24 885mm ² (38in ²)
203mm (8in)	255mm (10in)	32 365mm ² (50in ²)
254mm (10in)	303mm (12in)	50 670mm ² (79in ²)
304mm (12in)	353mm (14in)	72 583mm ² (113in ²)
355mm (14in)	404mm (16in)	19 980mm ² (154in ²)

Note that metric dimensions are actual design figures throughout this publication. Imperial dimensions are approximate rounded equivalents.

Description

Composition and manufacture

All lengths and fittings are twin-walled with a 25mm cavity. The outer case is joined to both the male and female couplers, while the inner liner is connected only to the upper male coupler, allowing the liner to expand or contract as the flue gas temperature varies without affecting the structural performance of the outer and removing the need for expansion components such as bellows etc. The SMW product utilises a mineral wool insulating medium providing an optimum and carefully controlled density of 260Kg/m², which in addition to providing safe operation at high temperature, also maintains a relatively high flue gas temperature throughout the chimney length, enabling the provision of a rapidly established and stable draught. Lengths and fittings utilise a rapid one-eighth turn twist action locking system at the joint, allowing simple and rapid installation of the product. A toggle clip locking band must then be fitted to finish each joint.

Application

SMW is primarily designed for use on domestic and commercial solid, multi-fuel, oil and gas appliances such as stoves, boilers and heaters operating under dry and negative draught conditions where the flue gas temperature will not exceed 450°C.

The chimney system should be installed in accordance with the requirements of BS 7566 Parts 1 to 4: "Installation of factory-made chimneys to BS 4543 for domestic appliances" and, depending on where used in the United Kingdom, the requirements of: Document "J" of the Building Regulations, Section "F" of the Building Standards (Scotland), Section "L" of the Building Regulations (Northern Ireland). For gas fired appliances of rated input not exceeding 60kW, reference should also be made to BS 5440 Part 1. The SMW product is CE Marked to BS EN 1856-1 to the designation detailed on page 2. SMW is also manufactured under a Quality Assurance Scheme certificate No. FM01079 administered by British Standards in accordance with BS EN ISO9001:2000. CE Certificate No. 0086-CPD-496040. SMW is also listed by HETAS as an approved chimney for solid fuel.

Installation

Installation instructions are on pages 10 and 11 and are provided with all support components. These should be consulted to accurately determine the components that are required to enable any installation to be correctly assembled.

Joining

All lengths and fittings are designed to be installed with the male coupling uppermost. Joints are achieved simply by placing the female coupling over the male coupling and making a one-eighth turn. A Locking Band must be used to secure every joint and to ensure a firm connection.

Connection to the appliance outlet

The Adaptor and the Adaptor for Cast-Iron Pipe are designed to make the connection to the appliance flue gas outlet or to a section of flue pipe to Building Regulation requirements.

Supports

The weight of the chimney may be carried by a number of components according to whether the chimney is installed internally or externally, and whether it is supported by the roof, ceiling, floor or external wall. These components include the Wall Support, Ceiling Support, Roof Support, Telescopic Floor Support and Ventilated Ceiling Support. Lateral stability is provided by Wall Bands, Bracing Brackets or Guy Wire Brackets.

Supporting free-standing chimneys:

Irrespective of roof configuration, where the chimney exceeds 1.5m beyond the last support it must be braced with steel bracing rods or preferably angle iron. Guy wires should only be used where alternatives are not possible. In either case, a Guy Wire Fixing Bracket should be used and secured above a Locking Band as close to the joint as possible. Where the chimney is supported by a mast consult SFL.

Roof support

The Roof Support is designed for supporting the chimney on the roof joists and is provided with adjustable gimbal plates. Bracing Brackets should be used in the roof space to restrain movement of the chimney due to wind forces on the chimney above the roof.

Load bearing performance

The weight of the chimney supported depends on the support components employed: the Table B on page 11 provides support details.

Weight characteristics

The table below indicates average weight of each diameter per metre run installed, excluding support components.

	127mm	152mm	178mm	203mm
SMW	6.7kg	8.2kg	9.7kg	11.2kg
	254mm	304mm	355mm	
SMW	14.5kg	17.0kg	19.5kg	

Clearance

The relatively low external casing temperature experienced in normal operation permits installation with only 50mm air gap clearance to combustible material. However, where the SMW Chimney passes through a combustible floor or ceiling and serves a solid/multi-fuel or oil fired appliance where the flue gas temperature exceeds 250°C, a Ventilated Firestop and Ventilated Ceiling Support MUST be used to maintain the 50mm clearance and act as a firestop.

Lengths of chimney

Standard lengths of 1000mm, 500mm, 300mm and 120mm as well as two adjustable lengths are available. Please see individual component tables for further information.

Restrictions on elbows

15°, 30° and 45° Insulated Elbows are available for use where it is not possible to construct a vertical chimney. Building Regulations dictate that no part of a chimney should form an angle greater than 45° from the vertical, except where it may be necessary to use a very short horizontal section of flue to connect the chimney to a back outlet appliance. Additional restrictions also apply on angles. See paragraph 8 of the Installation Instruction on page 10.

Floor and ceiling penetrations

Where the chimney penetrates a combustible floor or ceiling, a 50mm air gap clearance must be maintained, and the opening fire-stopped. Where SMW is used for solid and multi-fuel applications and where the flue gas temperature is greater than 250°C, the ventilated support and fire stop components must be used as detailed on pages 6 & 7. For oil and gas applications where the flue gas temperature is below 250°C or where the chimney passes through a non-combustible floor the Ceiling Support and Firestop Spacer can be used.

The combination of lengths used must be such that no joint occurs within the thickness of any floor or ceiling construction, and where connected to a flue pipe serving solid fuel, multi-fuel or oil fired appliances, the chimney must project at least 150mm below the ceiling before the connection to the flue pipe is made.

SFL Patented Intumescent Ceiling Support

The Ventilated Ceiling Support utilises a patented intumescent matrix. In the event of a fire in the appliance room, the intumescent matrix rapidly expands to close off the ventilation slots and form a fireproof barrier, stopping the potential spread of fire to the first floor area.

Fire Rating

The SMW product in accordance with the stability and integrity criteria of BS 476: Part 20 is fire rated for a period of 120 minutes.

Roof penetrations

Flat and Adjustable Flashings are available to provide the appropriate weather cover where a chimney penetrates the roof. Both types are fabricated from sheet aluminium.

The flat flashing is suitable for flat or nearly-flat roofs. The Adjustable Flashing is available in two types, for low- or steeper-pitched roofs. Both types of Adjustable Flashing are available with the flashing base constructed from malleable alloy for use with heavily-contoured roof tiles (to special order). Storm Collars are supplied with sealant and should be placed over the pipe immediately above the flashing. They are screw-clamped over the pipe and must be sealed to its outer wall with a waterproofing sealing compound. Alternatively, the Seldek Flashing system, manufactured in EPDM is available (see separate literature).

Terminations

Four types of termination are available. All have a female coupling and are fixed to the top of the chimney length and secured with a Locking Band. The insulated Top Stub provides a neat finish to the top of the chimney where a Rain Cap is not required. The Rain Cap is a domed stainless steel cap. The Round Top allows rapid exhaust of combustion products and its integral skirt deflects the wind. For gas fired appliances, the Gas Terminal is available for diameters 127mm to 350mm.

Product handling

The products are relatively easy to handle, but care should be taken when holding, fitting or assembling any part of the system. Users are advised to take suitable precautions, gloves etc., to avoid injury on any sharp exposed edges.

Design Information

SFL offers a comprehensive chimney sizing and design service to the trade and distribute through a geographic network of specialist distributors and national merchants. SFL cannot accept responsibility for any installation or application, which seeks to combine the SMW chimney with any other form of chimney construction.

Product Warranty

The SFL SMW chimney system is covered by a manufacturing defects warranty for a period of 10 years, subject to written conditions, copies of which are available on request.

Note

Those components within the SMW range which are fabricated from only a single skin, can be vulnerable when exposed to the products of combustion from solid fuel appliances. In the majority of cases, an open-ended terminal better suits appliance performance, but it is acknowledged that on occasions, other types of terminal from the SMW range have to be used to reduce rain entry. The Condensate Collector and the Locking Plug when used with solid fuel are also vulnerable to flue gas by-products, particularly if the chimney is not regularly maintained and cleaned. Such components are considered sacrificial and their life expectancy will vary dependant on application, location, maintenance and fuel usage. For that reason, the Rain Cap, Round Top, Condensate Collector and Locking Plug are not covered by any warranty other than for a twelve month period against defective manufacture.

It should be noted that chemically contaminated combustion air will affect the durability and therefore longevity of both the chimney and the appliance it serves. It is also advised **NOT** to use chemical chimney cleaners as evidence shows that these products can also reduce the life of the chimney and lead to corrosion of the liner. It is also recommended where the SMW product is installed near coastal locations that any external part of the chimney is protected from the salt environment by means of a suitable protective coating over the external surface.

Individual components

All Product Codes should be prefixed as follows:

127mm - 178mm diameters - 01 203mm - 355mm diameters - 02

Lengths

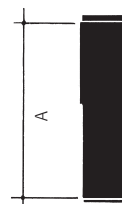
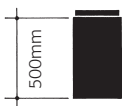

A (mm)

INTERMED 200 - 325
LONG 350 - 530

Straight lengths

Fixed straight lengths are available in four lengths: 120mm, 300mm, 500mm and 1000mm. Actual length of component is 32mm greater. Please note that no lengths are provided with Locking Bands.

	Code Nos. SMW			
	120mm	300mm	500mm	1000mm
127mm	10605	41105	41005	40905
152mm	10606	41106	41006	40906
178mm	10607	41107	41007	40907
203mm	10608	41108	41008	40908
254mm	10610	41110	41010	40910
304mm	10612	41112	41012	40912
355mm	10614	41114	41014	40914

Adjustable Lengths

A telescopic section designed to provide small increments in lengths between two fixed points. Two versions are available to provide maximum flexibility, ie, INTERMEDIATE (200mm-325mm adjustment) and LONG (350mm-530mm adjustment). The components are NOT load-bearing. Self-tapping screws are provided to secure the overlap once the required length has been determined. Because the component's application, and therefore performance, cannot be accurately controlled, it should be used internally and, in any event, never positioned so that the external skin is nearer than 305mm from any combustible material.

Size	Code Nos.	
	INTERMED	LONG
127mm	44005	41205
152mm	44006	41206
178mm	44007	41207
203mm	44008	41208
254mm	44010	41210
304mm	44012	41212
355mm	44014	41214



Locking Band

Used at all joints between chimney lengths or lengths and fittings.

Size	Code No.
127mm	08605
152mm	08606
178mm	08607
203mm	08608
254mm	08610
304mm	08611
355mm	08614

Fittings

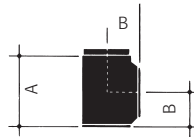

90° Tee

Used at base of vertical chimney. Can be used on the base or branch to provide access.

Size	Dimensions		Code No. SMW
	A	B	
127mm	298	149	14305
152mm	324	162	14306
178mm	349	175	14307
203mm	375	187	14308
254mm	425	213	14310
304mm	476	238	14312
355mm	526	263	14314

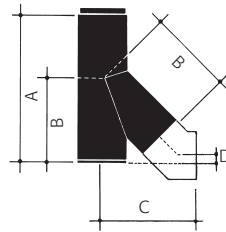

135° Tee

Used at base of vertical chimney. Can be used on the base or branch to provide access.

Size	Dimensions				Code No. SMW
	A	B	C	D	
127mm	500	311	368	30	41305
152mm	500	341	398	35	41306
178mm	500	378	433	42	41307
203mm	1000	408	463	47	41308
254mm	1000	466	522	57	41310
304mm	1000	526	584	66	41312
355mm	1000	588	645	77	41314

Dimensions "C" & "D" apply where Tee is used with 45° Elbow

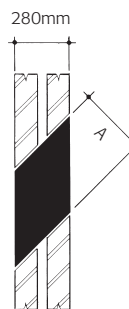

Wall Sleeve

Must be used where 135° Tee is used to pass the chimney through an external wall. The sleeve component provides, in effect, an uninterrupted run through the wall.

Size	Dimensions	Code No.
	A	
127mm	200	07105
152mm	225	07106
178mm	256	07107
203mm	280	07108
254mm	328	07110
304mm	378	07112
355mm	429	07114

Condensate Collector

Provides a removable trap for condensation and soot/debris under an Insulated Tee and is locked into the Female Coupler under the Anchor Plate. Easily removed to provide cleaning access. Uninsulated and non-Load bearing, it incorporates a stainless steel drain tube and cap having a 25mm bore and a 1" BSP external thread. This component must be secured with a Locking Band.

Size	Code No.
127mm	53205
152mm	53206
178mm	53207
203mm	53208
254mm	53210
304mm	53212
355mm	53214



Locking Plug

Used to seal and provide access on a female connection of a length or fitting.

Size	Code No.
127mm	19105
152mm	19106
178mm	19107
203mm	19108
254mm	19110
304mm	19112
355mm	19114

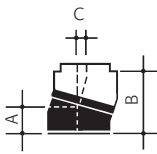

15° Elbow

Used to provide offsets or bends.

Size	Dimensions			Code No. SMW
	A	B	C	
127mm	87	342	45	31405
152mm	92	362	48	31406
178mm	97	381	50	31407
203mm	102	401	53	31408
254mm	113	447	58	31410
304mm	124	487	64	31412
355mm	134	527	69	31414

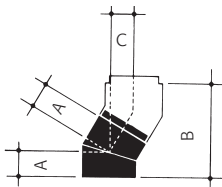

30° Elbow

Provides a 30° bend; or, by using two components, a 60° or variable offset bend can be obtained.

Size	Dimensions			Code No. SMW
	A	B	C	
127mm	87	325	87	32305
152mm	92	343	92	32306
178mm	97	362	97	32307
203mm	102	381	102	32308
254mm	113	422	113	32310
304mm	124	463	124	32312
355mm	134	500	134	32314

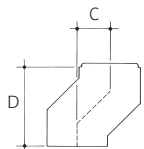

45° Elbow

Provides a 45° bend; or, by using two components, a 90° or variable offset bend can be obtained.

Size	Dimensions				Code No. SMW
	A	B	C*	D	
127mm	87	210	123	297	32205
152mm	92	222	130	314	32206
178mm	97	234	137	331	32207
203mm	102	246	144	348	32208
254mm	113	273	160	386	32210
304mm	124	299	175	423	32212
355mm	134	324	190	458	32214

* maximum offset



Adaptor

Used to connect appliance flue outlets or vertical or horizontal single-wall flues to insulated chimneys.

Size	Dimensions		Code No.
	A (I.D.)		
127mm	128		19405
152mm	153		19406
178mm	179		19407
203mm	204		19408
254mm	254		19410
304mm	305		19412
355mm	356		19414

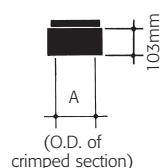

Adaptor for Cast-Iron Pipe

Used to connect boiler flue outlets or cast-iron or mild-steel flue pipes to insulated chimney lengths. The crimped inner lining fits inside the pipe or outlet and, where the outer casing fits outside the flue or outlet, it should be caulked with a fire cement compound.

Size	Dimensions		Code No.
	A (I.D.)		
127mm	114		19505
152mm	140		19506
178mm	165		19507
203mm	190		19508
254mm	241		19510
304mm	292		19512
355mm	343		19514

102mm Adaptor

Used on a 102mm boiler to connect to a 127mm Straight Length or fitting.

Size	Code No.
127mm	29705

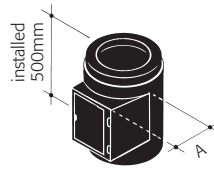

Inspection Length

Used to provide access for inspection or cleaning. A recessed square catch prevents unauthorised use. Access may also be provided to the chimney using a 90° Insulated Tee with a Locking Plug in the branch. Where used with solid, multi-fuel or oil-fired appliances, a 150mm air-gap clearance must be maintained from the outer surface of this component to any combustible material.

Size	Dimensions		Code No. (140 x 200mm)
	A		
127mm	148		41805
152mm	160		41806
178mm	175		41807
203mm	188		41808
254mm	212		41810
304mm	237		41812
355mm	263		41814



Separate detail sheet and instruction available on request

Flue Draught Stabiliser

Designed to be used with any SFL Flue system where excessive draught is likely to create combustion problems. Where used with the SMW Chimney System, the Stabiliser should be applied with the Appliance Adaptor, Code No. 194, (in turn located onto the 90° Tee branch).

To fit flue Ø	Code No.
150mm	3192006
175mm	3192007
203mm	3192008
250mm	3192010
300mm	3192012
350mm	3192014

Special Fittings

Flexible Liner Adaptor

Used where SMW connects an appliance to an existing chimney which is to be lined. Lower end of this connects to standard product. The upper end incorporates a socket/stub designed to accommodate flexible chimney liner.

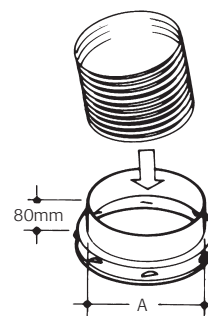

Size	Dimension A	Code No.
127mm	134	50105
152mm	161	50106
178mm	187	50107
203mm	218	50108
254mm	263	50110
304mm	313	50112
355mm	364	50114

Modular Tees

Designed for use with modular boiler installations and other applications where a manifold or horizontal header is required. Can be manufactured to order in any standard pipe size; number, size and orientation of pipe sizes required.

Trim Plate Collar

Polished stainless steel circular collar with a 100mm wide flange to provide a neat finish at the ceiling or where exposed internal chimneys meet the appliance.

Size	Code No.
127mm	08505
152mm	08506
178mm	08507
203mm	08508
254mm	08510
304mm	08512
355mm	08514

Flashings & Terminals

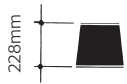

Top Stub

Secured with a Locking Band.

Size	Dimensions			Code No.
127mm				17305
152mm				17306
178mm				17307
203mm				17308
254mm				17310
304mm				17312
355mm				17314

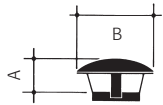

Rain Cap

Secured with a Locking Band.

Size	Dimensions		Code No.
	A	B	
127mm	127	254	07405
152mm	143	305	07406
178mm	165	356	07407
203mm	183	406	07408
254mm	229	508	07410
304mm	273	610	07412
355mm	319	712	07414

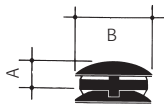

Round Top

Secured with a Locking Band.

Size	Dimensions		Code No.
	A	B	
127mm	96	254	07505
152mm	110	305	07506
178mm	127	356	07507
203mm	144	406	07508
254mm	179	508	07510
304mm	214	610	07512
355mm	248	712	07514

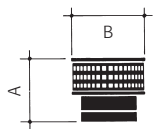

Gas Terminal

This component is for use where the system is used on gas fired appliances. Secure with a Locking Band.

Size	Dimensions		Code No.
	A	B	
127mm	93	236	52405
152mm	93	267	52406
178mm	220	295	52407
203mm	220	322	52408
254mm	220	370	52410
304mm	220	422	52412
355mm	220	472	52414

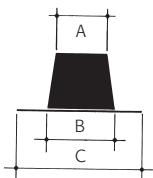

Flat Flashing

For flat or nearly-flat roofs.

Size	Dimensions			Code No.
	A	B	C*	
127mm	190	280	495	70000007
152mm	210	300	495	70000009
178mm	240	330	610	70000010
203mm	260	350	610	70000011
250mm	310	400	610	70000012
300mm	360	450	660	70000013
350mm	410	500	762	70000014

* base is square (C x C)

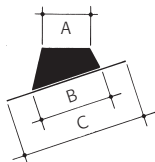

5°-30° Adjustable Flashing

Size	Dimensions			Code No.
	A	B	C*	
127mm	190	281	495	70053007
152mm	210	304	508	70053009
175mm	240	335	550	70053010
203mm	260	361	578	70053011
250mm	310	419	610	70053012
300mm	360	476	678	70053013
350mm	410	533	762	70053014

* base is square (C x C)

32°-45° Adjustable Flashing

Size	Dimensions			Code No.
	A	B	C*	
127mm	190	375	578	70324507
152mm	210	403	610	70324509
175mm	240	428	650	70324510
203mm	260	475	678	70324511
250mm	310	546	737	70324512
300mm	360	617	820	70324513
350mm	410	689	889	70324514

*base is square (C x C)

**The degree of malleability is limited. Excessively corrugated or profiled roofs could exceed the limitations of the malleable flashings.

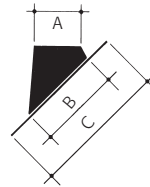

Alternatively, the Seldek range of flashings, manufactured in EPDM material are available. See separate brochure for details.

Storm Collar

Used as a weathering over flashing and supplied with sealant.

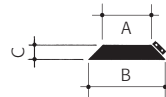

Size	Dimensions			Code No.
	A	B	C*	
127mm	177	280	70	70123407
152mm	202	301	70	70123409
175mm	227	330	70	70123410
203mm	252	351	70	70123411
250mm	302	401	70	70123412
300mm	352	451	70	70123413
350mm	402	501	70	70123414

Support Components (Gas & Oil <250°C)

The following components MUST be used where SMW is used on gas or oil fired appliances where the Flue Gas Temperatures do not exceed 250°C and/or where the chimney system penetrates a non-combustible floor.

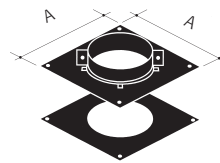

Ceiling Support

Provides a 50mm air gap clearance to a penetrated floor or ceiling and is only used where SMW penetrates a non-combustible floor, and/or serves a gas or oil fired appliance where flue gas temperatures do not exceed 250°C.

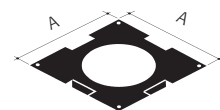

Firestop Spacer

Used to provide location, fire and dust stopping where SMW is used through non-combustible and combustible floors when serving gas or oil fired appliances ONLY with a flue gas temperature not exceeding 250°C. These components are supplied singly but are usually in pairs and are not Load bearing.

Size	Dimensions A	Code No.
127mm	330	08705
152mm	355	08706
178mm	381	08707
203mm	406	08708
254mm	457	08710
304mm	507	08712
355mm	558	08714

Support Components (Solid Fuel/Oil >250°C)

The following components MUST be used where SMW is used on Solid Fuel and Oil fired appliances where Flue Gas Temperature exceeds 250°C and/or where the chimney system penetrates a combustible floor.

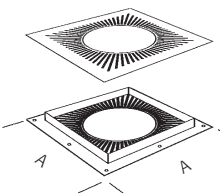

Ventilated Fire Stop

This component MUST always be used where SMW is used internally on Solid Fuel or Oil fired appliances producing Flue Gas Temperatures exceeding 250°C and passes through combustible floors where the sections below the floor penetration are enclosed within a compartment.

Size	Dimensions A	Code No.
127mm	379	88705
152mm	399	88706
178mm	429	88707
203mm	453	88708

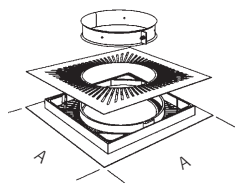

Ventilated Ceiling Support

This component MUST always be used where SMW is used internally on Solid Fuel or Oil fired appliances producing Flue Gas Temperatures exceeding 250°C and passes through the first combustible floor above the heating appliance. Fitted with an intumescent matrix.

Size	Dimensions		Code No.
	A		
127mm	379		88305
152mm	399		88306
178mm	429		88307
203mm	453		88308

The above ventilated components are of patented design as UK Patent 2388651.

Fixings & Supports

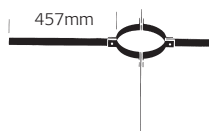

Bracing Bracket

Used to provide lateral stability to a chimney passing through the roof space.

Size	Code No.
127mm	09805
152mm	09806
178mm	09807
203mm	09808
254mm	09810
304mm	09812
355mm	09814

Universal Wall bands

Used for lateral support with no more than 3.5m externally and 4.0m internally between centres. The galvanised wall band is intended for internal applications only, where as the stainless steel version can be used for both internal and external applications.



Size	Dimensions		Code No.
	A*	B	
127mm	138	136	3115155
152mm	163	148	3115205
178mm	188	161	3115234
203mm	213	173	3115255
254mm	271	200	3115305
304mm	321	225	3115355
355mm	371	450	3115405

Size	Dimensions		Code No.
	A*	B	
127mm	138	136	3116155
152mm	163	148	3116205
178mm	188	161	3116234
203mm	213	173	3116255
254mm	271	200	3116305
304mm	321	225	3116355
355mm	371	450	3116405

*fixing centres

Guy Wire Bracket

Wires are not provided. Rigid Stays preferred. Structural calculations should be made for each application. See installation instructions.



Size	Code No.
127mm	09205
152mm	09206
178mm	09207
203mm	09208
254mm	09210
304mm	09212
355mm	09214

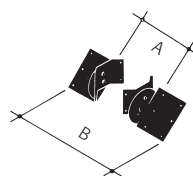

Roof Support

Provided with adjustable gimbal plates to permit a chimney to be supported on roof joists, trussed rafters etc. Maximum suspended chimney length supported is 6m and maximum total length supported is 9m.

Size	Dimensions		Code No.
	A*	B	
127mm	280	490	02900
152mm	304	515	02900
178mm	330	545	02900
203mm	356	570	02900
254mm	406	618	02900
304mm	456	688	02900
355mm	506	719	02900

*minimum distance between roof trusses

Telescopic Floor Support

Used to support chimney at floor level.

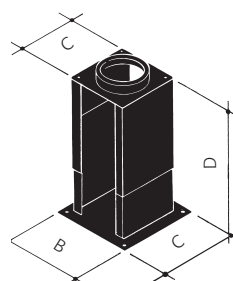

Size	Dimensions				Code No.
	A	B	C	D	
127mm	246	340	290	300-550	02605
152mm	271	365	315	300-550	02606
178mm	296	390	340	300-550	02607
203mm	322	416	366	300-550	02608
254mm	371	465	415	300-550	02610
304mm	421	515	465	300-550	02612
355mm	471	565	515	300-550	02614

Mounting Plate for Precast Chamber or Lintel

Designed to be used when connecting SMW chimney to a Lintel.

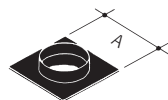

Size	Dimensions		Code No.
	A		
127mm	210		52705
152mm	235		52706
178mm	261		52707
203mm	286		52708
254mm	337		52710
304mm	387		52712
355mm	438		52714

Adjustable Wall Support

Designed to be internally or externally applied to provide either initial or intermediate support for the chimney. Maximum supported chimney lengths are detailed on page 11.

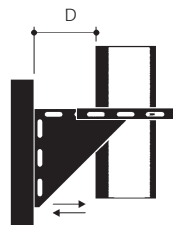

Size	Code Number	
	Stainless Steel	Galvanised
127mm	0151705	0199805
152mm	0151706	0199806
178mm	0151707	0199807
203mm	0251708	0299808
254mm	0251710	0299810
304mm	0251712	0299812
355mm	0251714	0299814

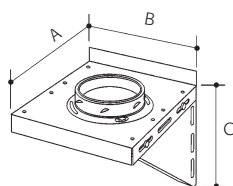

Size	Dimensions			
	A	B	C	D
127mm	282	311	279	150
152mm	302	331	299	150
178mm	331	360	328	200
203mm	355	384	352	200
254mm	403	432	399	220
304mm	453	482	449	267
355mm	504	533	500	293

Typical Installations

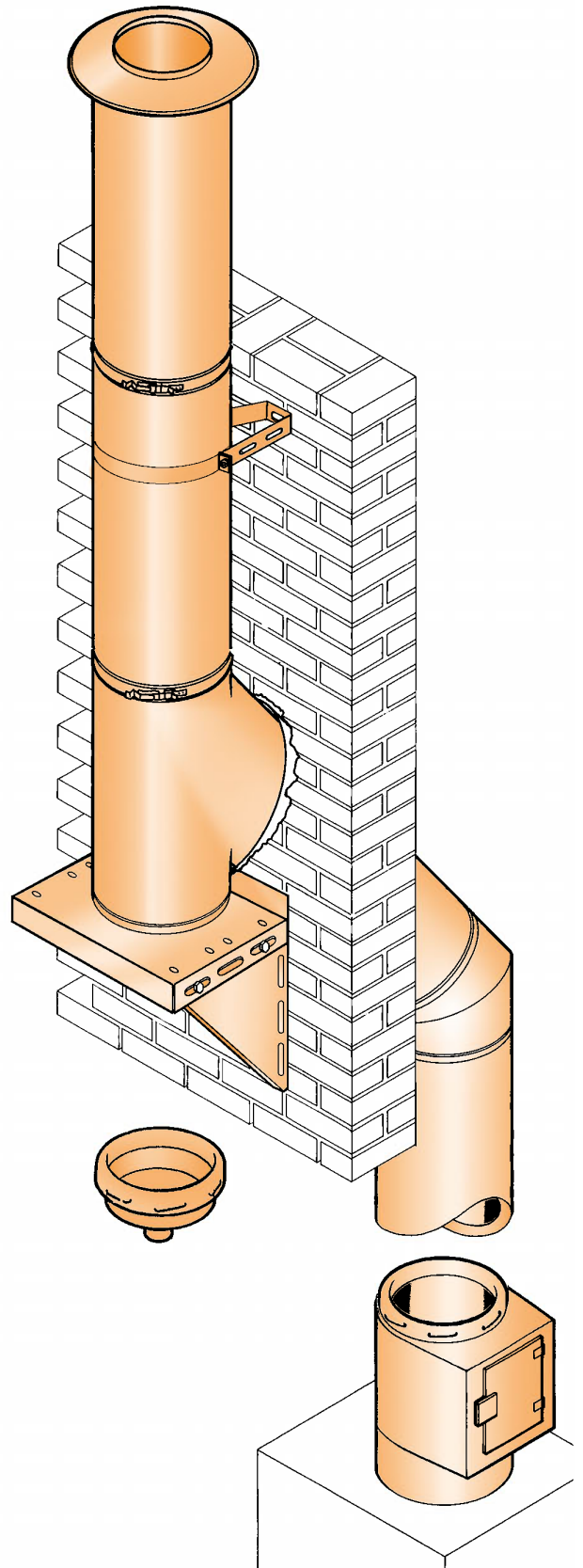
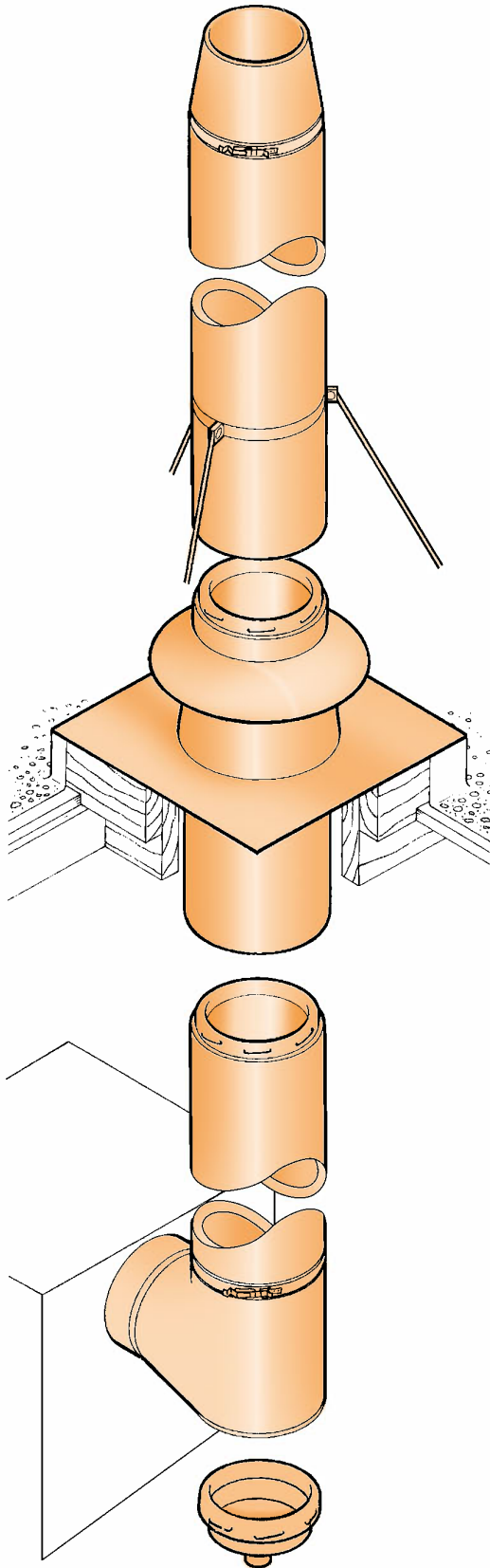

Typical Applications

Where the chimney passes through the roof space, it is essential that it is adequately supported by bracing to roof timbers. If there is a chimney run of more than 1.5m from the Ceiling Support to the Roof Support, use a Bracing Bracket and rigid stays for such an application.

It is a Building Regulation requirement that any prefabricated chimney arrangement in an accessible roof must be enclosed such that combustible materials cannot come into contact with the outer skin of the chimney. A minimum air gap clearance of 50mm can be maintained using cladding or a wire frame.

Chimney joints must not be positioned in the thickness of floor or ceiling joist spaces or within 150mm of floor/ceiling.

Building enclosure must maintain a 50mm air gap clearance from combustible materials, and with no combustible material within the enclosure (See instructions 5 & 7).

The chimney must project 150mm below ceiling level before flue pipe connection is made. It is very important that if a spigotted flue pipe is used, the lower end of the Adaptor does not rest on the shelf of the spigot. Allow at least 15mm for expansion of the flue pipe, and whatever the configuration, seal the joint with fire cement and fibre rope or suitable alternatives.

For solid fuel back or side flue outlet, the maximum legally permitted length of horizontal chimney or flue pipe is 150mm.

Fig. 4

No more than ONE offset in the chimney, (not including the connection to the appliance). The length of chimney between Elbows MUST NOT exceed 20% of the total chimney length.

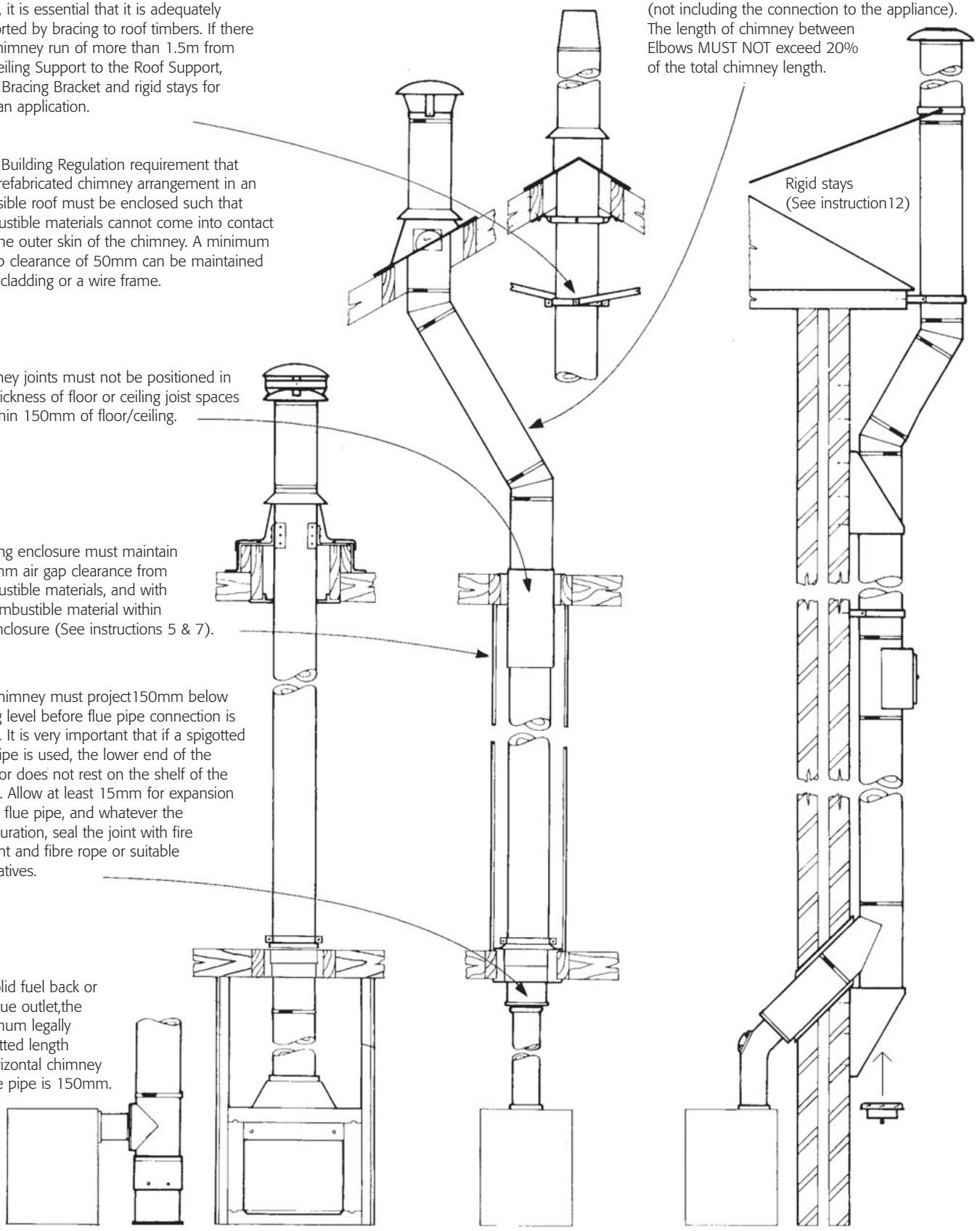

Fig. 1

Fig. 2

Fig. 3

Fig. 5

Apply these illustrations with the instructions on the next page.

Installation instructions

- 1 It is important to consult with the Building Regulations and, where the equipment served exceeds 150kW, the Clean Air Memorandum if appropriate.
- 2 To conform with Building Regulations, ensure that either an Inspection Length or an Insulated 90° or 135° Tee is used to provide easy access to the chimney for inspection and cleaning (unless such inspection and cleaning can be achieved through the appliance).
- 3 The internal diameter of the chimney must conform to the requirements of the heating appliance manufacturer's instructions and should not, under any circumstances, be less than the diameter of the appliance outlet. The height of the chimney will depend on the building structure with which it is used. However, not less than 4.5 metres chimney height from the top of the appliance is considered the minimum height for solid fuel appliance use. In any event, SFL have available Technical Data which provides chimney sizing criteria for any configuration.
- 4 Each chimney section and associated fitting shall be used as manufactured for assembly on site without any alteration or cutting. Sections and components are easily secured together with an eighth of a turn twist-lock which provides a sturdy and neat joint. Make sure that the elements are installed the right way up, with the male coupler uppermost. Once assembled, Locking Bands must be fitted to every joint. No special tools or sealing compounds are required.
- 5 Where used with SOLID FUEL or OIL appliances producing flue gas temperatures exceeding 250°C, the clearances at floor/ceiling joists must be established using the **Ventilated Ceiling Support** and the **Ventilated Firestop**.

All of these components incorporate spacers which are designed to provide a minimum 50mm air gap clearance from combustibles. This distance **MUST** be maintained elsewhere in the system between the outer case of the chimney and any combustible materials. Do not place any additional insulation material around any part of the chimney, and in all cases, the system must be designed so that no joints between chimney elements occur within the thickness of a floor space. Where used with GAS appliances, a minimum air gap clearance must be maintained between combustibles and the outside skin. For installation and
- 6 Joints between floors. The selection of chimney elements should be made so that no joints occur within the thickness of a floor space.
- 7 Where serving Solid Fuel or Oil appliances, any part of the chimney which passes through any room other than that in which the appliance using the chimney is situated, should be protected to prevent both damage and the accidental location of combustible materials against the outer skin. It is a Building Regulation requirement that ANY factory made insulated chimney should be enclosed where passing through a cupboard, storage space or accessible roof space. Any such enclosure must be constructed of materials and applied in such a way that they can be considered as providing access to the chimney. In the case of SMW, the 50mm air gap clearance applies.
- 8 No part of the system should be constructed at an angle greater than 45° from the vertical. The only permitted exception is where it is necessary to use an angle of 45° to make the connection to an appliance, which can be direct or with the use of a suitable flue pipe. The latter arrangement can be constructed using the 135° Tee as illustrated in these instructions. Where a change of direction or offset is required, 15°, 30° and 45° Elbows should be used within the limitations earlier mentioned. **NOTE.** Building Regulations will not permit more than ONE offset in any chimney run, (ie 2 Elbows). However, that excludes any Elbows used to make the connection to the appliance. Where an offset is used, the length of chimney between two elbows **MUST NOT** exceed 20% of the total length of the chimney.
- 9 The chimney must be adequately supported with the system support elements. Where externally used, the chimney must be supported on a wall or mast. (For latter applications, seek further details from SFL). The external support components must be used at intervals depending on the load-bearing criteria quoted in Table B. Wall Bands are not load-bearing and should be provided at intervals not exceeding 3.5 metres external and 4.0 metres internal for lateral stability only. Where used externally the stainless steel wall band should be used.
- 10 Where an external installation requires the chimney to offset past a roof overhang, Elbows should be used to form an angle as shallow as possible.
- 11 Connection to the appliance can either be direct using the Adaptor or a length of flue pipe can be connected to the Adaptor. In all cases, all joints between flue pipes/appliance outlets/chimney must be securely caulked and sealed with fibre rope (or suitable alternative) and fire cement. ANY flue pipe connection to the chimney **MUST** be made in the same room as the appliance.
- 12 The outlet of the chimney must comply with Building Regulations, where appropriate. Fig 6 indicates the requirements for solid fuel and oil served appliances. See IL Gas Vent Installation Instructions for Gas served appliance termination requirements.

Under most circumstances, the above regulations will permit the normal operation of the chimney. However, should it be necessary to construct the chimney so that it extends beyond 1.5 metres above the roof or last support, such extension must be provided with additional support. A Guy Wire Bracket should be clamped to the chimney for this purpose, to which rigid stays, preferably angle iron, should be connected.
- 13 The terminals illustrated are suitable for all fuels, with the exception of the Gas Vent Terminal. For such applications please refer to separate IL Gas Vent System Installation Instructions for details.
- 14 If painting of the chimney is desired, first thoroughly degrease and then dry and prime the surface; in the case of galvanised components, use a zinc chromate based primer. Apply a finishing coat of external quality paint as required. NB: Do not paint the chimney where it is internally positioned 50mm from combustible materials.

NB: It is strongly recommended that any galvanised components that are externally applied, are thoroughly protected by painting or suitable alternative.

Framing and Load Bearing Data

Table A: Framing Data

The following data provides the opening required in all floor and ceiling areas. All details in mm.

Chimney Size	127	152	178	203
External Diameter	175	203	230	255

Ventilated Firestop and Ventilated Ceiling Support

Overall Plate Size	373sq	399sq	429sq	453sq
Framing Size*	278sq	304sq	333sq	359sq

* Includes plasterboard lining of the timber frame.

Table B: Load Bearing Data

The weight of the chimney can be borne in a number of ways and this table states the minimum length of chimney that can be supported by the various components. All details in metres.

Component	127	152	178	203	250	300	350
Ceiling Support	6	6	6	6	6	6	6
Vent Ceiling Support	6	6	6	6	6	6	6
Telescopic Floor Support	16.7	16.7	16.7	16.7	16.7	16.7	16.7
Roof Support	9*	9*	9*	9*	9*	9*	9*
Inspection Length	16.7	16.7	16.7	16.7	16.7	16.7	16.7
90°Tee	16.7	16.7	16.7	16.7	16.7	16.7	16.7
135°Tee	10.7	10.7	10.7	6.7	6.7	5.9	5.9

* Part of the flue up to a maximum of 6m may be suspended beneath the roof support.

NB: Wall Bands are not load-bearing and must be used at intervals not exceeding 4m internally and 3.5m externally.

Wall Support Brackets

Diameter (mm)	Non-Inverted		Inverted	
	Closed	Open D>50	Closed	Open D>50
127	30	25	30	30
152	30	25	30	30
178	25	20	30	22
203	25	15	30	22
254	25	15	30	22
304	25	15	25	17
355	25	15	25	17

All details in metres.

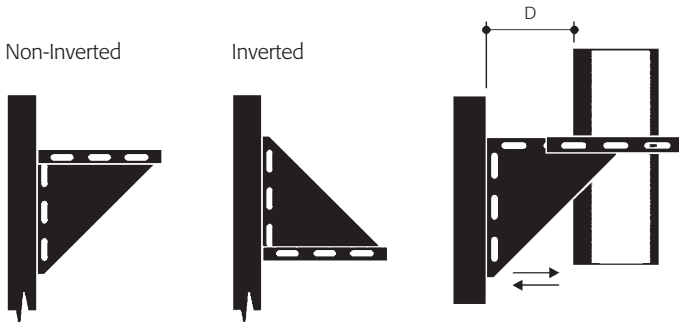

Chimney Termination

Fig. 6

The illustration and table identify the minimum requirements as dictated by Building Regulation where the chimney is used with solid fuel, wood or, if vapourising burner fitted, an oil-fired appliance.

A chimney terminal over a pressure jet oil-fired boiler must discharge a minimum 600mm above the roof penetration point, or any adjacent structure, if it is with 750mm. It must also be at least 600mm from any opening into the building and 300mm, from any combustible material. If the chimney extends more than 1.5m above last support, it must be supported with rigid stays.

See IL Gas Vent literature for details of legal termination requirements where SMW is used for gas fire-fired appliances of rating up to 70kW.

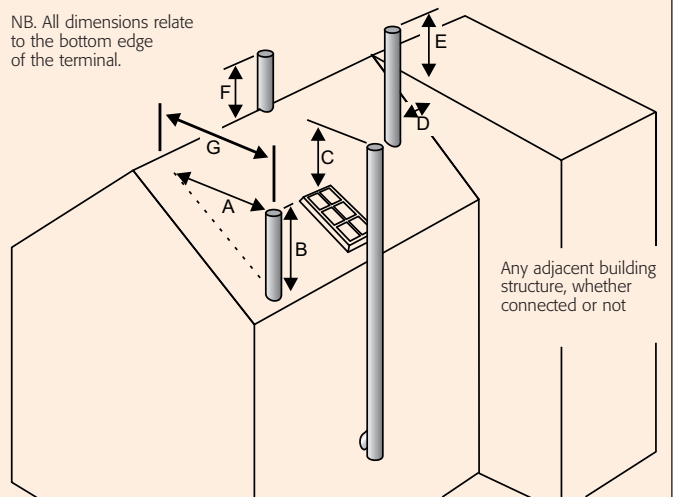

Dimension	Minimum distance measured from the top of the chimney construction, excluding any pot or terminal.
A	2.3 metres horizontally clear of the roof surface, eg. if the roof pitch is 45°, then the chimney should project 2.3 metres above it.
B	1 metre, provided A is satisfied, or 600mm above the ridge if G is less than 600mm.
C	1 metre above the top of any flat roof, and the top of any openable roof light, dormer window or ventilator, etc., if it is located within 2.3 metres.
D/E	If D is less than 2.3 metres, E shall be not less than 600mm.
F	600mm above the ridge.
G	Edge of chimney to roof ridge.

The information contained in this brochure was accurate at the date of publishing. However the company reserves the right to introduce at any time modifications and changes of details as may be necessary. To avoid any misunderstanding, interested parties should contact the company to confirm whether any material alterations have been made since the date of this brochure.



UK Sales and Customer & Export Services

SFL, Pottington Business Park, Barnstaple, Devon EX31 1LZ
Tel: 01271 326633 Fax: 01271 334303 www.sfl.uk.com info@sfl.uk.com
SFL is a division of Powmatic Ltd.